

ZPX

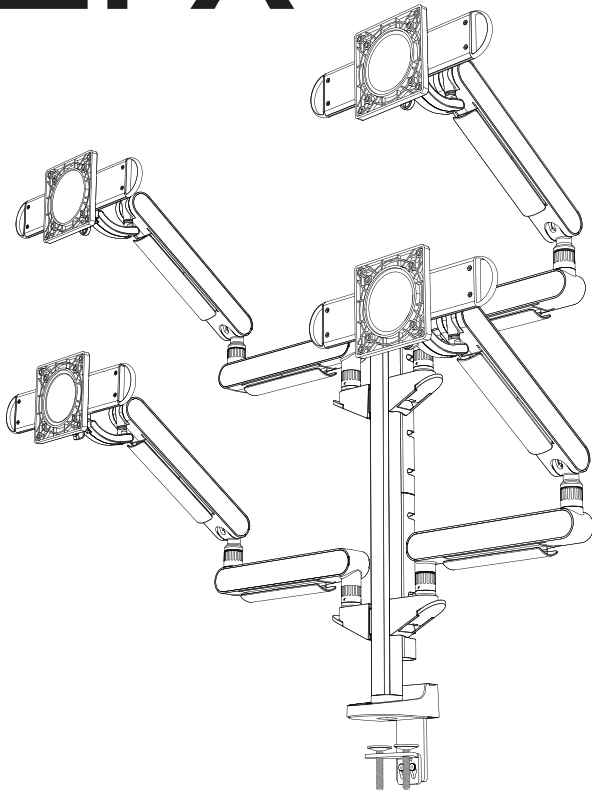

ergoCentric® + zgonic

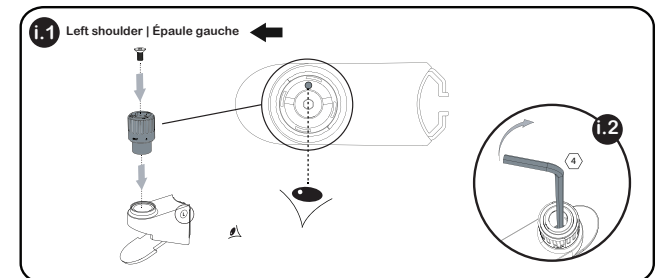
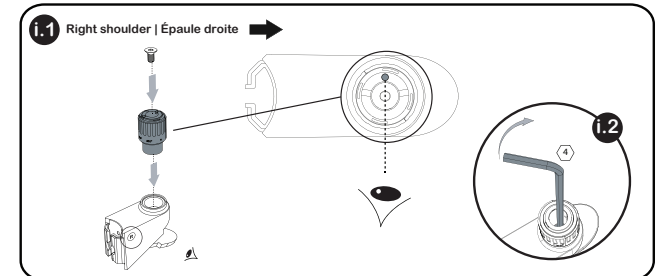
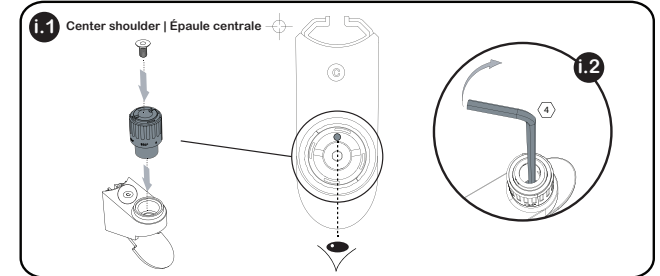
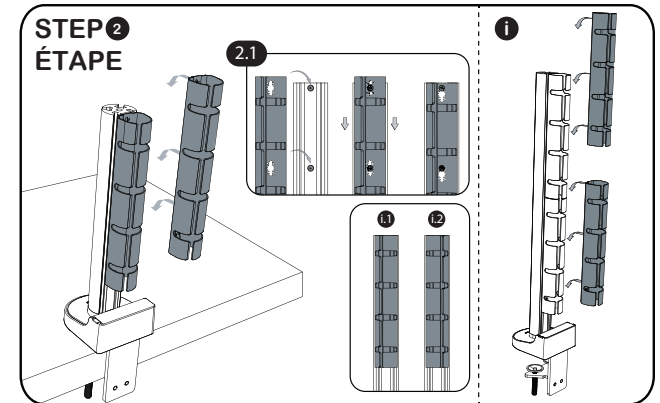
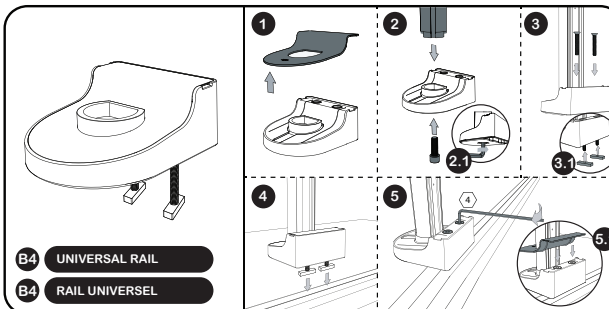
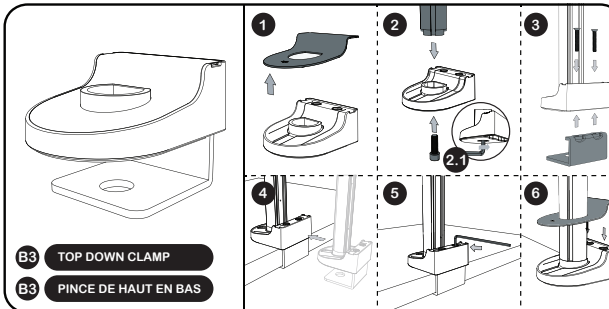
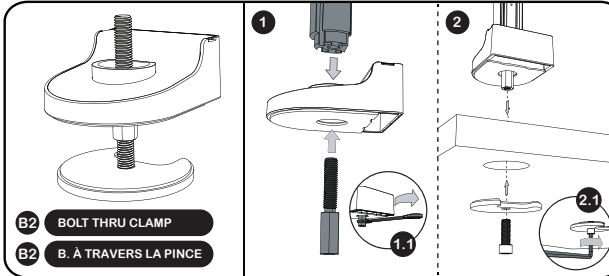
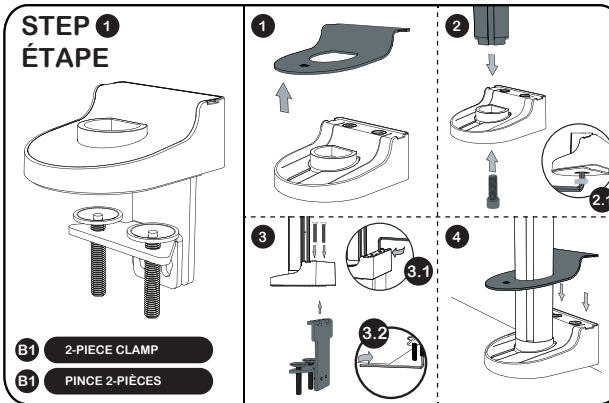

WARNING! Stored Energy Hazard:
The arm mechanism is under tension and will move up rapidly, on its own, as soon as attached equipment is removed. For this reason, **DO NOT** remove equipment unless the arm has been moved to the highest position! Failure to follow this instruction may result in serious personal injury and/or equipment damage!

AVERTISSEMENT! Risque d'énergie accumulée:
Le mécanisme du bras est sous tension et remontera rapidement, de lui-même, dès que l'équipement fixé sera retiré. Pour cette raison, **NE PAS** retirer l'équipement avant que le bras n'ait été placé dans sa position la plus haute! Le non-respect de cette instruction peut entraîner des blessures graves et/ou endommager l'équipement!

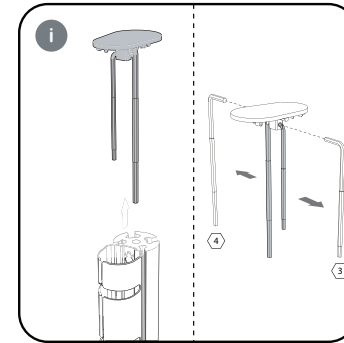
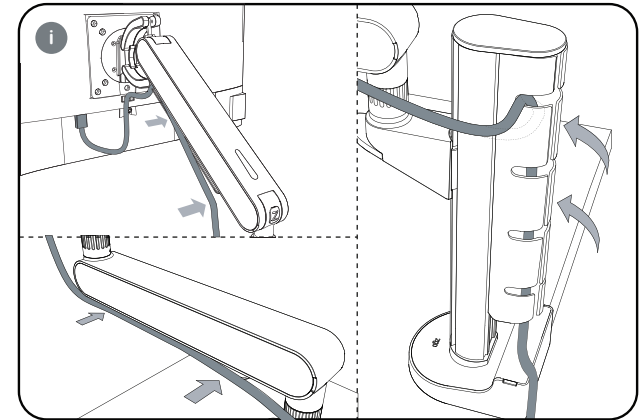
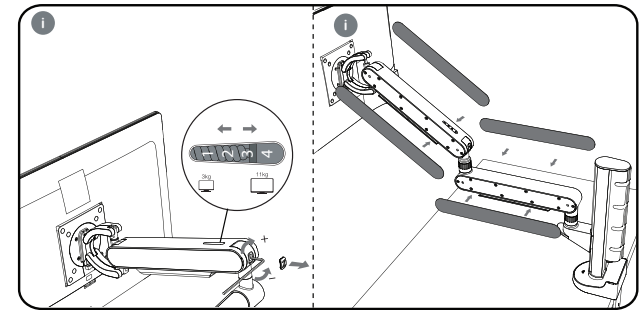
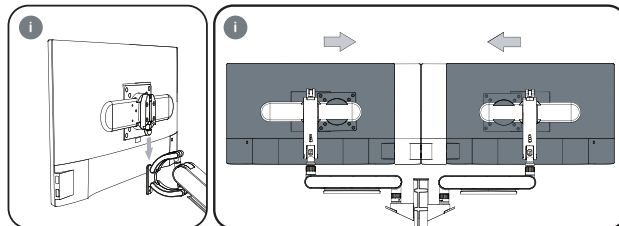
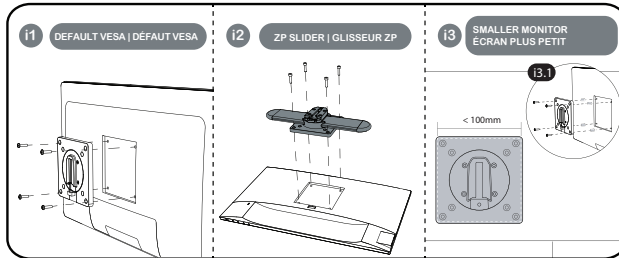
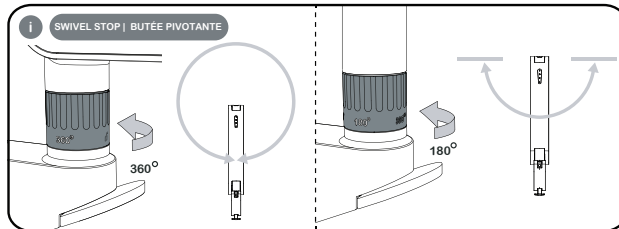
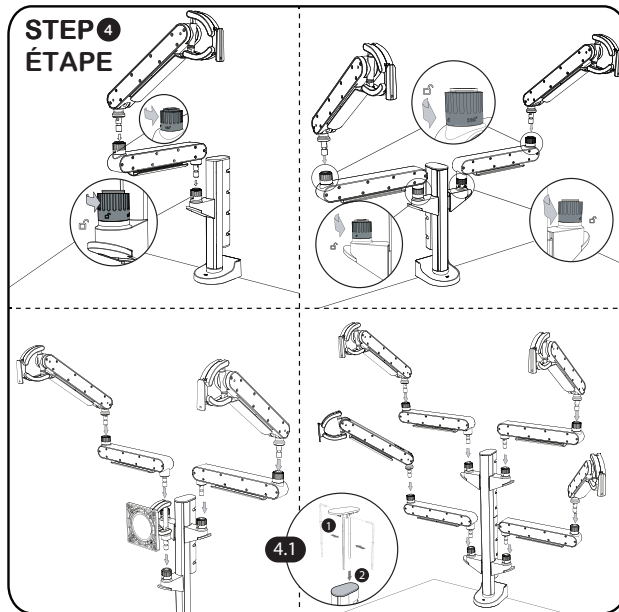
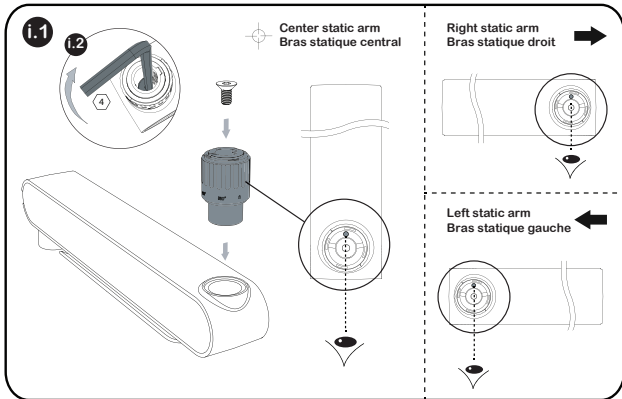
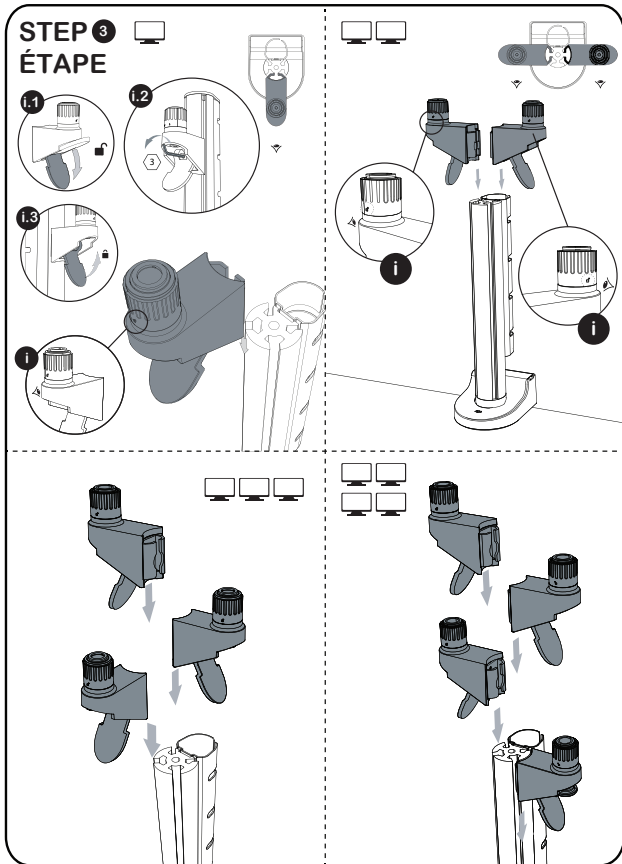

ergoCentric® + zgonic