

2lbs Weight Plate Plaque lestée de 2 lb

Assembly Instructions
Instructions D'assemblage

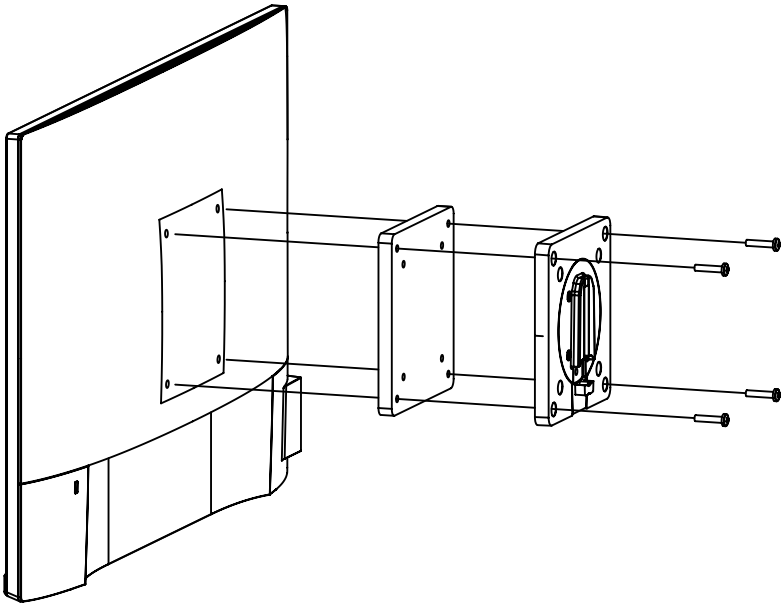

ergoCentric®

The science of sitting®
La science de l'assise®

2lbs Weight Plate - Plaque lestée de 2 lb

Parts - Pièces Détachées

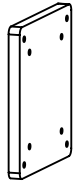

(1)
2lbs Weight Plate
Plaque lestée de 2 lb



(2)
M4x20



(3)
M4x25



(4)
Spacers | les entretoises*
* Parts from VESA Plate

Assembly Instructions - Instructions D'assemblage

Step 1: Place Weight Plate (1) on the VESA mounting point, located at the back of the monitor.

Étape 1: Placer la plaque lestée (1) sur le point de montage de la plaque VESA, situé au dos de l'écran.

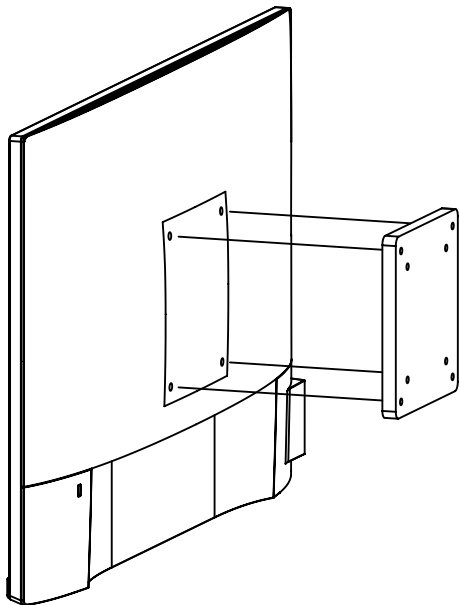

2lbs Weight Plate - Plaque lestée de 2 lb

Step 2: Install the VESA plate on top of the Weight Plate with M4x20 screws (2) going through the plate and into the monitor VESA mounting point.

Note: Monitors with an inset VESA mounting point will require using M4x25 screws (3) and the provided spacers (4).

Étape 2: Installer la plaque VESA sur la plaque lestée en faisant passer les vis M4 x 20 (2) à travers la plaque et dans le point de montage VESA de l'écran.

Note: Les écrans dont le point de montage sur la plaque VESA est encastré requièrent vis M4x25 (3) et les entretoises (4) fournies.

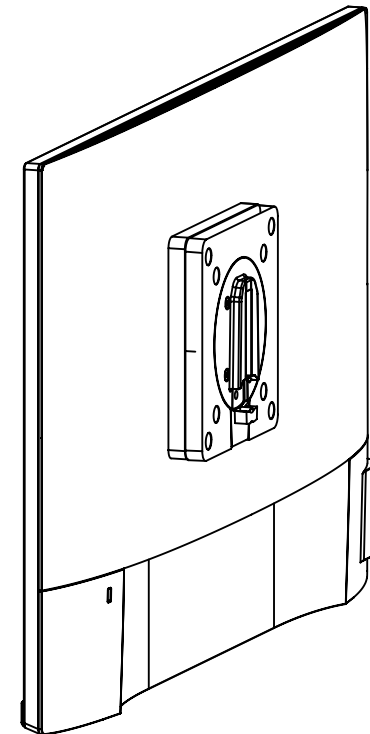

ergoCentric®

ph | tél. : 1 866 GET ERGO (438-3746) | 905 696-6800

fx | téléc. : 1 800 848-5190 | 905 696-0899

service@ergocentric.com

ergocentric.com

ergoCentric® is a registered trademark of ergoCentric Inc.
ergoCentric® est une marque déposée d'ergoCentric Inc.