

# Training Table

---

## Assembly Instructions



ergoCentric®

# Training Table

## Parts

---

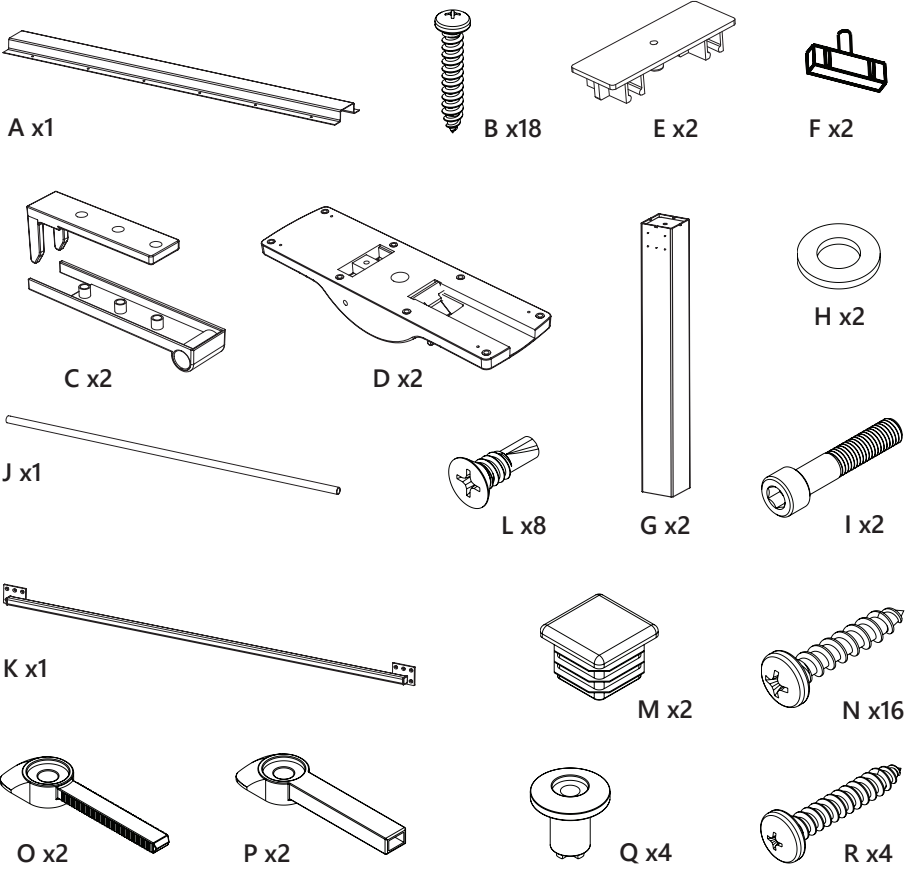

## Feet

---

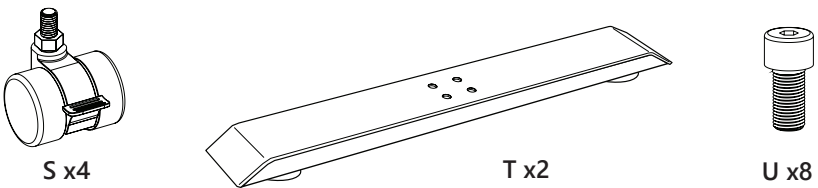

# Training Table

## Preparing the tabletop

---

**Step 1a:** Lay tabletop on floor or work area with decorative laminate faced down and brown underside faced up.

**Step 1b:** Identify your tabletop size.

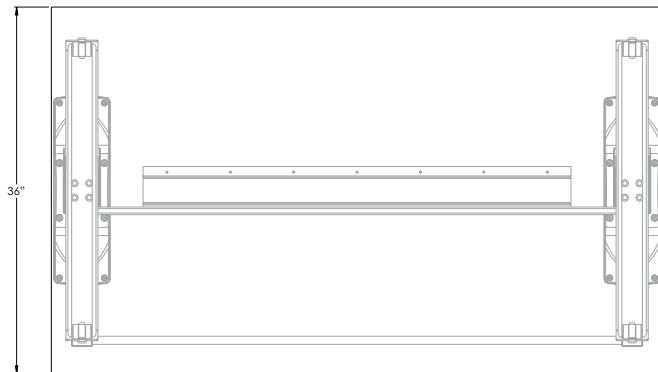
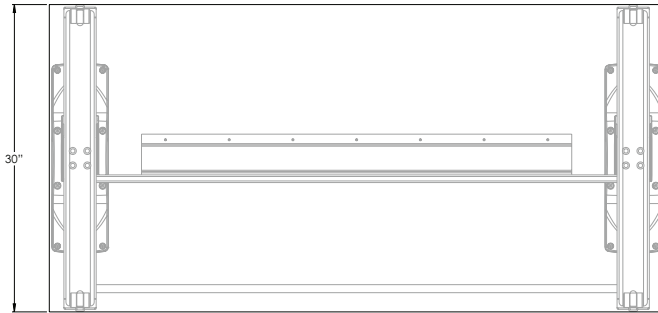
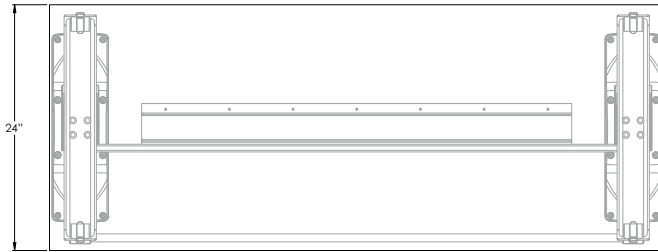

# Training Table

## Assembly Instructions

**Step 2:** Align under-table support (A) with pilot holes and secure with #8x7/8" (B) wood screws.

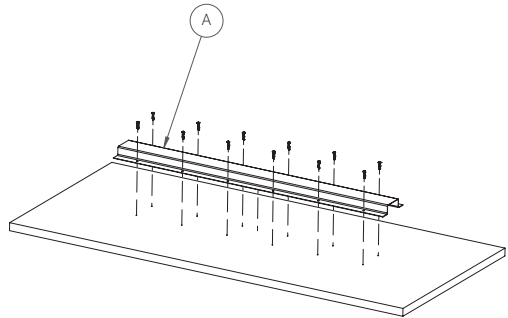

### Step 3: Assemble Brackets

**Step 2a:** Snap Part 1 and Part 2 of the Release Assembly (C) together, ensuring that the holes align according to your tabletop size.

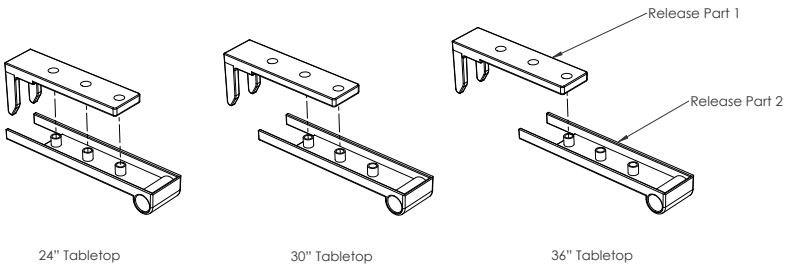

**Step 3b:** Press the Release assembly into the designated groove within the Folding Bracket (D).

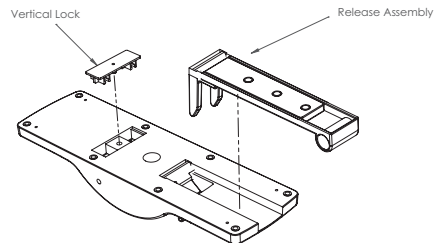

**Step 3c:** Insert the white plastic Vertical Lock (E) into the rectangular cutout. Press until the top surface is flush with the Folding Bracket.

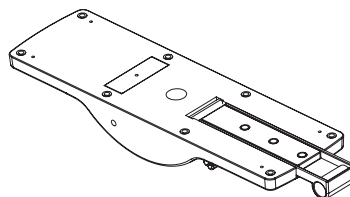

# Training Table

**Step 2d:** On the bottom side of the Folding Bracket, insert the Wedge (F) piece into the outer hole of the rectangular slot. Apply pressure until secured.

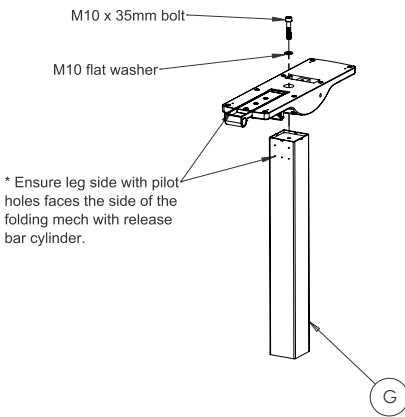
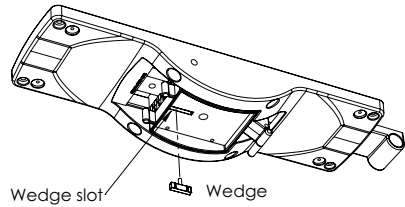

## Step 4: Attach Bracket

Secure the Folding Bracket to the leg (G) using M10 washer (H) and bolt (I) provided. Ensure that the leg is squared up with the bracket and that the pilot holes are situated on the side nearest the release cylinder, as shown.

## Step 5: Assemble Frame

With the folding bracket fastened to the leg, turn both leg assemblies upside down and release the legs so they are in the folded down position.

Set leg assemblies on underside of tabletop and slide either end of release bar (J) into folding brackets.

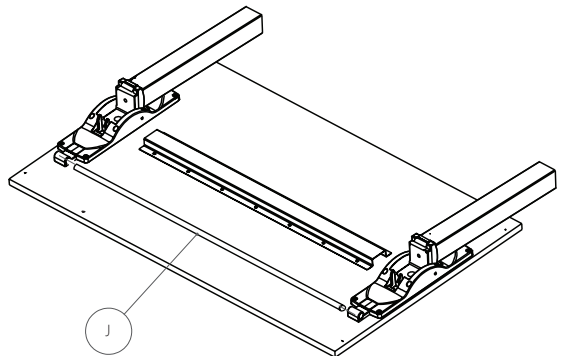

# Training Table

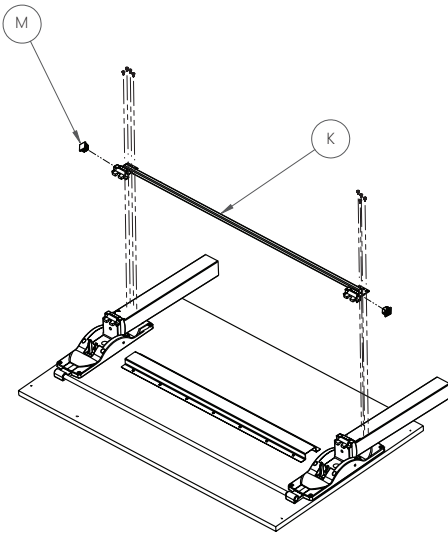

**Step 5b:** Align leg support bar (**K**) with pilot holes on legs. Fasten with self-tapping screws (**L**).

**Step 5C:** Insert plug (**M**) into both ends of support bar.

**Step 6:** Align frame with pilot holes then secure legs with M6x35mm (**N**) screws.

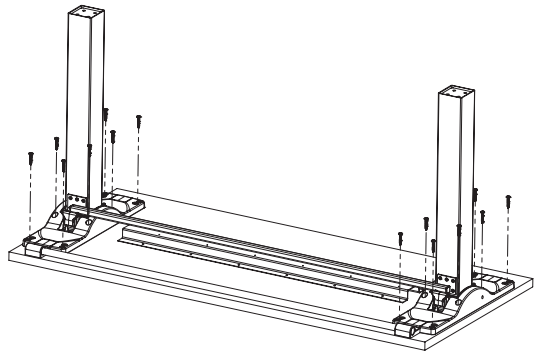

**Step 7:** Attach both male (**O**) and female (**P**) ganging connectors to folding mechanism using inserts (**Q**), and screws (**R**).

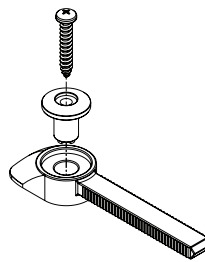
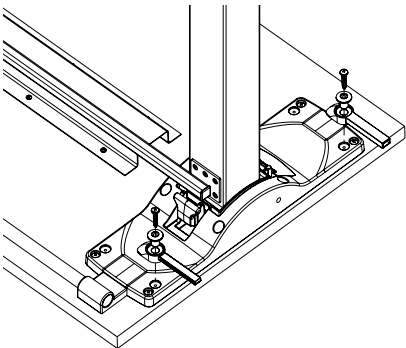

Male

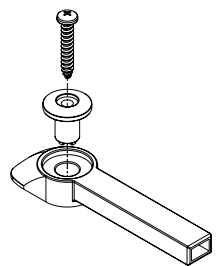

Female

# Training Table

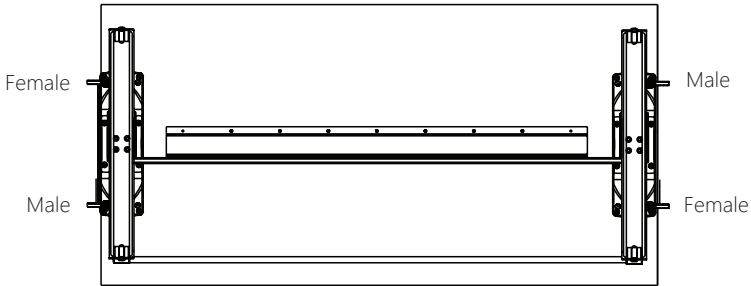

**Step 7a:** Attach ganging connectors to outer edge of each Release Assembly.

**Step 8:** Unscrew both glides from each foot, then screw in casters (S).

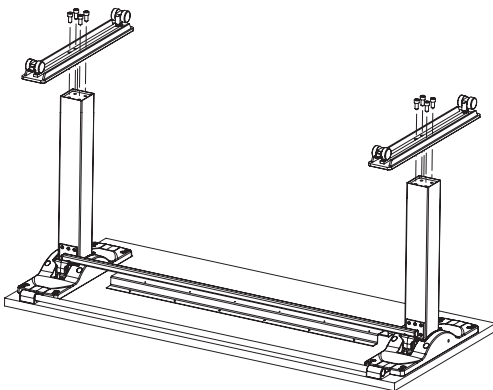
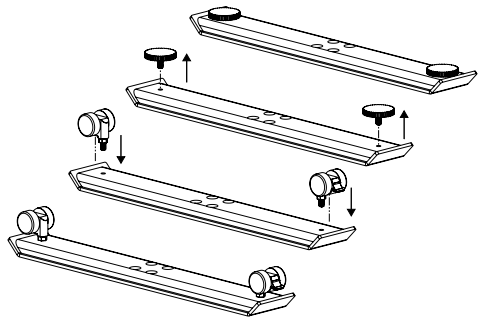

**Step 9:** Place foot upside down on the bottom of the leg tube so that the long edges of the foot and folding mechanism run parallel to each other.

Attach feet (T) to leg (G) using bolts (U).



# ergoCentric®

ph: 1 866 GET ERGO (438-3746) | 905 696-6800

fx: 1 800 848-5190 | 905 696-0899

[service@ergocentric.com](mailto:service@ergocentric.com)

[ergocentric.com](http://ergocentric.com)

ergoCentric® is a registered trademark of ergoCentric Inc.